



F & A UPDATE

Volume 5.5

March, 1998



Message from the Controller

There are some very complicated laws regulating payments to non-resident aliens. Further, it is imperative that you plan in advance so that when your guest arrives the payment process will go smoothly. Citizens and resident aliens are responsible for paying their own taxes and are liable for any errors and omissions. However, when making payments to non-resident aliens (NRAs) **the individual or institution paying them is responsible for any taxes due.** This means that if we fail to withhold taxes on payments to a NRA and that individual fails to file a tax return and pay the required taxes, UCF is liable for the full amount of taxes due plus any fines, penalties and interest.

1. The Immigration and Naturalization Service admits aliens under a number of different visa types. Some of these visa types *do not allow* us to pay these individuals for services rendered - IT IS ILLEGAL! Some visa types only allow reimbursement of travel expenses and some allow all payment types.
2. NRAs must have a valid social security number or Individual Taxpayer Identification Number (ITIN), if they do not have one they must apply for one which can take six weeks or more.
3. IRS requires a number of forms be filed within certain time limits.

A form entitled, "Foreign National Information Form" must be completed prior to any payments being made. This form, once completed, will provide the necessary information to complete the payment process. To obtain written instructions, copies of required forms or for general questions, contact Ms. Beverly P. DeLong at 384-2029 or E-mail at BDeLong@mail.ucf.edu. Finance and Accounting stands ready to answer your questions and guide you through the process.

Remember, plan early (six to eight weeks minimum), 1) Complete the Foreign National Information Form. 2) Obtain a copy of the visa and INS 94 card and have them notarized. 3) Make sure they have a valid social

security card number or ITIN and 4) Contact Finance & Accounting as soon as possible. Good Luck!

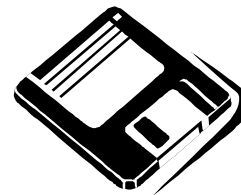

Cashiers

If your department receives payments to be deposited with the Cashiers office please make sure that they are made on a daily basis. Also, be sure you use the pre-numbered departmental receipt forms available in the Cashier's office. These receipts should be used in numeric sequence and all voids should be sent to the Cashiers office. A monthly report is generated indicating any receipts used out-of-sequence, this will be sent to your department for corrective action. If you have any questions, please contact Jackie Morales at x3-3120.



Property Inventory

We are about 84% complete in our annual property inventory as of February 28, 1997. If your area still has unscanned items, please make every effort to complete

this process. Florida Statutes require all state agencies to reconcile their property inventory records to the actual items on an annual basis. We would like to complete this process as soon as possible. Thanks to each area that has already completed their inventory for their diligent work. Those that are not yet complete please do so in the next few weeks. If you are not familiar with our On-Line Property System and would like individual training or have any questions, contact Mr. Jim Bray at X3-2457. You can register for the next regularly scheduled class by contacting Human Resources Training section at 275-4304.



Travel Information

1. When preparing a cash advance deposit slip, one of the following object codes should be used in order to return funds into its appropriate area:

If travel took place:	Object Code
In-State	269090
Out-of-State	269091
In Another Country	269092

2. When processing TARs On-Line, if the authorizer decides not to approve a travel request, it is the department's responsibility to delete the TAR from the system. Travel personnel do not have the ability to delete TARs on the on-line system.
3. It is the department's responsibility to inform travelers of travel policies and procedures as well as all state guidelines at the University. A lack of knowledge on the part of the traveler is not justification for non-compliance with these rules.
4. Approval of the President, or his designee is required before travel in excess of thirty (30) continuous days starts (foreign or domestic) (Rule 6C7-4.018). Several colleges/departments also require additional approvals, be sure to check with your Vice President, Dean, Chair or Director. Do not use the on-line TAR System for this type of travel.
5. When processing travel reimbursements for Puerto Rico, the full meal allowance of \$21 (\$3 for breakfast, \$6 for lunch and \$12 for dinner) or per diem (\$50 per day) is the authorized rate. Foreign per diem does not apply.

6. When processing a Travel Reimbursement Voucher, all pre-payments should be cross-referenced (short invoices, LPO's, etc.). Attach a readable copy of all payment requests to the reimbursement voucher.
7. The USTravel toll free after hours number is to be used by travelers who have already started their trip and then need to make changes or by persons needing next day emergency tickets (1-800-669-8787). The 24-hour hot-line number does not have the ability to issue tickets. If a ticket is needed in an emergency, USTravel can issue a prepaid ticket that will be waiting for the traveler at the airport. Airlines - not USTravel - charge an additional \$75 fee for Pre-Paid tickets. A voice mail phone system is scheduled to be installed by mid 1998 to better accommodate UCF travelers. We will let you know when this is available.

USTravel 1998 Holidays are:

Memorial Day	May 25 (Monday)
Independence Day	July 3 (Friday)
Labor Day	September 7 (Monday)
Thanksgiving Day	November 26 (Thursday) & November 27 (Friday)
Christmas Day	December 25 (Friday)

8. UCF travelers may use personal credit cards to pay for business travel. USTravel does not charge a fee for this service.
9. Departments must fax completed TARs (must include a TAR number) to USTravel for tickets to be issued.
10. When personal travel is included with business travel, the travel agent will advise the department or traveler of the cost of the personal travel, which must be deposited to the departmental account at the Cashiers office. The agent will also write a statement on the UCF invoice indicating the amounts of the personal and business travel. Please include the cashier's receipt with the Travel Reimbursement Voucher.
11. It is no longer necessary to submit a copy of the entire program/agenda of a conference/convention with the travel reimbursement. Clear copies of the pages that itemize the registration fee, meals, lodging, and dates of the conference/convention are required to be attached to the Travel Reimbursement Voucher.
12. When two or more travelers go to the same destination and one individual pays for both/all hotel charges, the individual paying the hotel bill should be reimbursed for the full amount paid to the hotel. Please prepare the reimbursement request accordingly and cross-reference all travelers' TAR numbers on each reimbursement vouchers.

13. Only original itemized hotel receipts showing the detail of charges and the amount of payment can be accepted.
14. When a hotel room cost is \$100 (before taxes) or more in-state or \$150 or more out-of-state, justification for the amount is required. Justification must indicate a valid reason why cheaper accommodations could not be obtained and shall not be solely for the comfort and convenience of the traveler.
15. Occasionally, a traveler gets receipts that have the wrong date on them. We will accept them if the correct dates are explained and signed.
16. When credit cards issued by the University are used for gasoline purchases, we must have a cash register receipt or credit card receipt *with the station imprint*. The total amount of the gasoline purchase must be readable. Gasoline can only be purchased for state or rental cars (not personal vehicles) and must have the car's tag number written on the receipt. When the department receives the credit card charge, the appropriate individual (approver must be on the Departmental Authorization List) must check the charges, noting the account number and TAR number and approving them for payment. The credit card charge slip should then be submitted to the Travel Section for payment. Dates of purchase must match travel dates on TAR.
17. When a traveler claims less than the full meal allowance (\$3 breakfast, \$6 lunch or \$12 dinner) or per diem (\$50 per day) an additional statement is required on the Travel Reimbursement Form. It should either state that the traveler realizes that they are aware that the reimbursement rate is less than allowed by statute and that they agree to accept this amount or writing "COMP" on to indicate the same thing.
18. The Group Travel Authorization, Form No. 41-553 should be used for all group travel. A group leader must be designated to expedite payment of expenses. Upon completion of the trip, a Group Travel Summary Report, Form No. 41-554 should be submitted within five working days to the Travel Section. All travel paid under the Group Travel procedures must comply with all existing travel rules and rates.
19. Short invoices with TAR numbers should be sent to the Travel Section for processing payment. However, the Purchasing Department must sign them first - prior to being sent to Finance and Accounting.

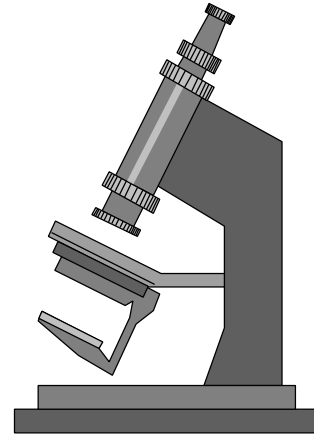

Contracts and Grants

The following are the new fringe benefit rates for contract and grant salary disbursements occurring after January 1, 1998, on accounts in the Sponsored Research Trust Fund. The following fringe benefit rates are for all salary/OPS personnel on established payroll lines. Please exclude consultants and independent contractors who offer services on a contract basis for a limited period of time. These rates are estimates for grant proposals only. Fringe costs are charged to each grant based on the individual employee's actual fringe benefits costs.

	A&P/ USPS	OPS Temp/Adjunct	Graduate Assistants
Retirement	17.43%		
Social Security	7.65%	7.65%	
Workman's Comp	0.17%	0.17%	0.17%
Unemploy. Comp	0.36%		
Health	4.99%		
State Life Ins	0.14%		
General Liability	0.00%		
DOA Per Assess	0.07%		
Annual/Sick Lea	0.00%		
Total	30.81%	7.82%	0.17%

Please note that these rates include an amount for terminating employees' accrued annual and sick leave. Beginning July 1, 1992, we have accumulated funds to be used to pay accrued leave amounts for terminating employees paid from Grant accounts.

NOTE: Rates are subject to change each January.

WHO TO CALL IN FINANCE & ACCOUNTING

12424 Research Parkway, Suite 300, Orlando, Florida 32826-3249

Plus 4 - 0975

Phone 384-2000

FAX #'s

Main Office 384-2015

Accounts Payable 384-2176

Travel Office 384-2177

ACCOUNTS PAYABLE

		PHONE #	GroupWise ID
Jim Horne	Accounts Payable & Travel Supervisor	384-2024	JHORNE
Evelyn Ramirez	A/P Processor's Supervisor-Vendors whose name begins with A, except Airborne, B, H, K, L, M, P, S, T, and Marriott and Contractual Payments, Contracts & Check Desk and Check Distribution	384-2040	ERAMIREZ
Oscar Canonizado	A/P Processor's Supervisor-Vendors whose name begins with Airborne, C, D, E, F, G, I, J, N, O, Q, R, U, V, W, X, Y, and Z	384-2039	OCANON
Millie Cunningham & Audrey Lane	A/P Processor-Vendors whose name begins with M and P	384-2034	CUNNINGM
Jacqui Christian & Siegi Elam	A/P Processor-Vendors whose name begins with G, O, Q, U, and Y	384-2037	CHRISTIJ
Linda Baker & Sheila Colaricci	A/P Processor-Vendors whose name begins with C, I, N, X, Z, and #'s	384-2038	BAKERL
Sherri Swallow & Laura Crouch	A/P Processor-Vendors whose name begins with D, E, J, R, and W	384-2035	SWALLOWS
Jamie DeVault & Maria Hodgekinson	A/P Processor-Vendors whose name begins with L and S	275-4371	DEVAULJ
Elsa Dantes & Dennis Frances	A/P Processor-Vendors whose name begins with A, except Airborne, and K	384-2002	EDANTES
Debra Wyatt & Jennifer Reese	A/P Processor-Vendors whose name begins with B, H, and T	384-2036	WYATTD
Lauren Williams Melissa VanKessel	A/P Processor-Vendors whose name begins with Airborne, F, and V	275-4316	WILLIAMSL

AUTHORIZED SIGNATURE LIST CONTROL

Mary Andersen	Authorized Signature List	384-2025	MANDERSN
---------------	---------------------------	----------	----------

AUXILIARY ACCOUNTS

John Shaw	Auxiliary & Reconciliation Supervisor	384-2028	JSHAW
-----------	---------------------------------------	----------	-------

BI-WEEKLY ON-LINE ID CHARGE INFORMATION

TBA	ID Transfers Accountant	384-2017	
-----	-------------------------	----------	--

TRAVEL OFFICE

Teresa Tharp	Travel Supervisor	384-2021	TTHARP
Alicia Mercado-Ruiz	Avis, B, I, O	384-2018	MERCADOA
Joey Modi	Gas Payments, American Express Applications, Athletics Dept., Mc, R, and U	384-2020	MODIJ
Oscar Cariaso	Thrifty, D, G, L, M, and Z	384-2019	CARIASOO
Lita Mercado	Advances, Class C Meals, E, H, N, T, V, W, and Y	384-2044	LMERCADO
Maria Barrios	Reimbursements, U.S. Travel, F, K, Q, and X	384-2042	MBARRIOS
Carmen Toledo	Reimbursements, All World, A, C, J, P, and S	275-4317	CTOLEDO